

CORTE AA
(S/Escala)

TOLERANCIAS GENERALES	
PIEZAS USINADAS	: ± 0,25 mm
PIEZAS FORJADAS	: ± 0,8 mm
PIEZAS EN CHAPAS	: ± 0,5 mm
ANGULOS	: ± 0,30°
MATAR CANTOS VIVOS	

NOTA: Acotaciones de soldaduras ver Planos NEFA 32.155, 32.157 y 32.204

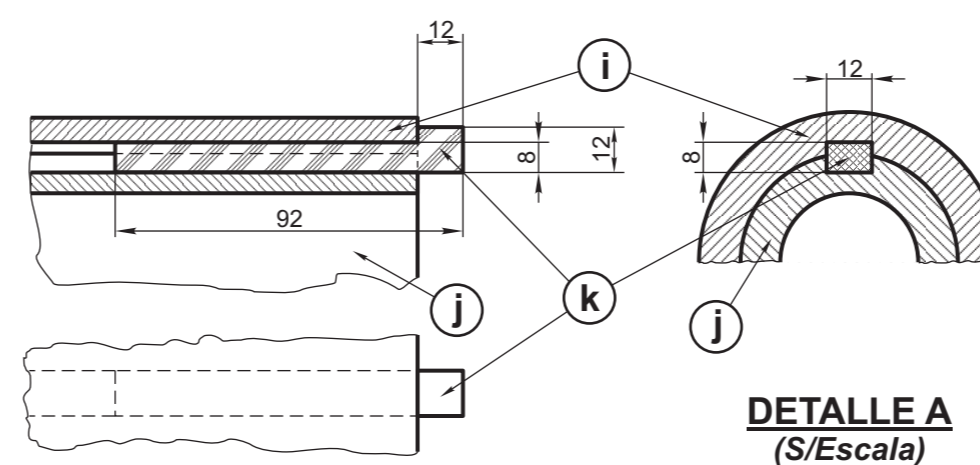
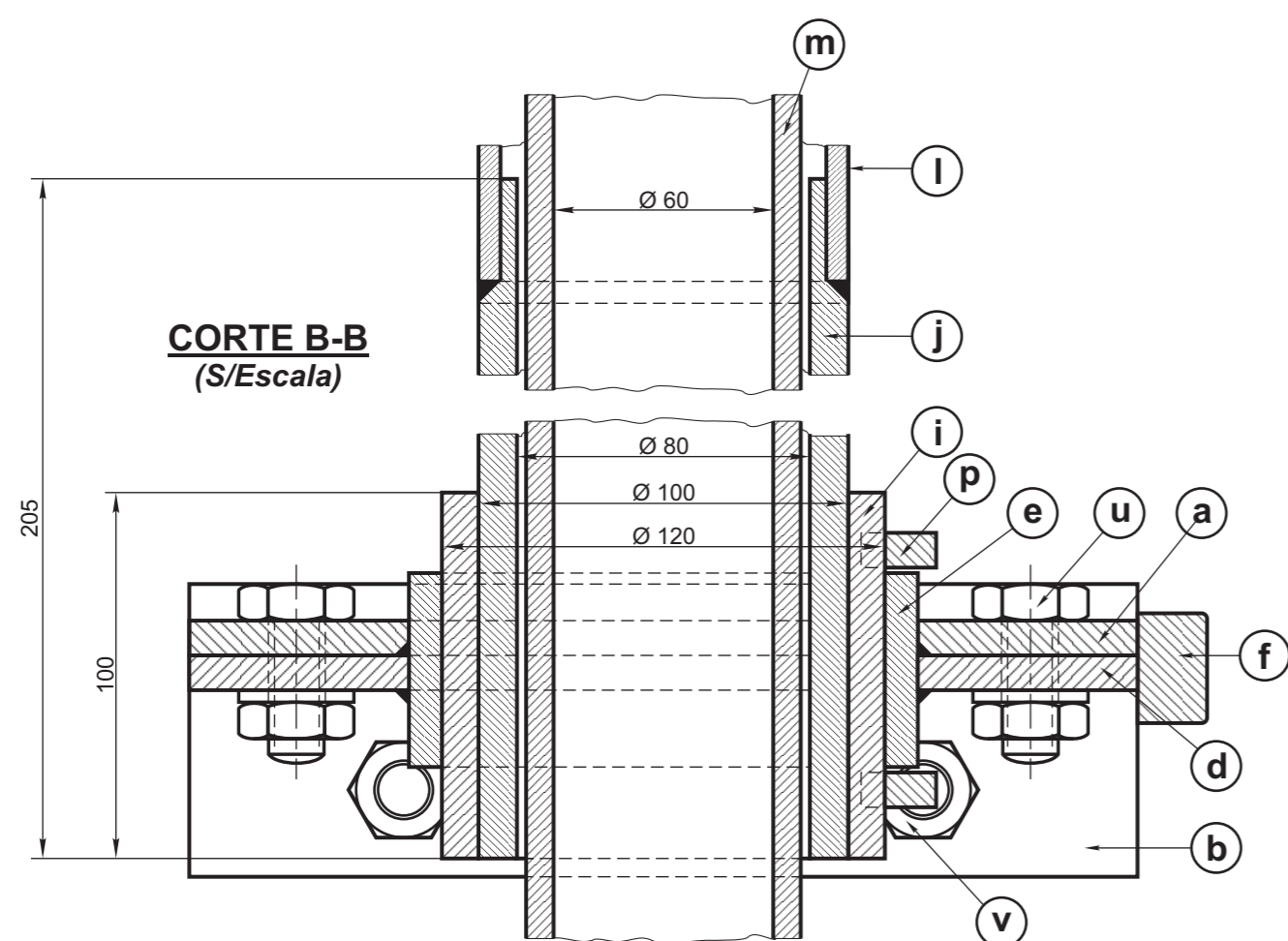

DETALLE A
(S/Escala)

v	Bulón Grower	4	E.R.E. Ø 15,8 x 40	
u	Bulón Grower y Plana	4	E.R.E. Ø 15,8 x 44,4	
t	Tapa puño	2	NEFA 32.190	
s	Puño p/leva coman.	2	NEFA 32.189	
r	Distanciador leva	4	NEFA 32.188	
q	Estribo de trinquete	2	NEFA 32.187	
p	Costados de levas	4	NEFA 32.184	
o	Pasador	2	NEFA 32.170	
ñ	Gatillo	2	NEFA 32.186	
n	Eje gatillo	2	NEFA 32.170	
m	Eje interior	2	NEFA 32.171	
l	Eje intermedio	2	NEFA 32.172	
k	Pasador c/talón	2	NEFA 32.180	
j	Buje	2	NEFA 32.178	
i	Buje	2	NEFA 32.183	
h	Leva de seguridad	2	NEFA 32.192	
g	Soporte de Artic.	2	NEFA 32.163	
f	Corona dentada	2	NEFA 32.162	
e	Medio cojinete	2	NEFA 32.166	
d	Armazón superior	2	NEFA 32.161	
c	Rzo. de soporte	2	NEFA 32.160	
b	Base soporte	2	NEFA 32.158	
a	Costado soporte	2	NEFA 32.159	
ITEM	DESCRIPCION	Cant.x Coche	ESCUADRIA, ESPECIFICAC. Y OBSERVACIONES	CATAL-NOMEN.

Dibujo		Fecha:		Proyecto		Controló		Aprobó		
VAGON TOLVA ABIERTO PARA PIEDRA DETALLE COMANDOS EJE INTERMEDIO				FERROCARRILES ARGENTINOS AREA MECANICA		ESCALA	TROCHA	LINEAS:	UTILIZACION	EMISION
					1676					
FIRMA Y FECHA APROB.				N° DE PLANO		NEFA 32.149				