

CONJUNTO ARMADO

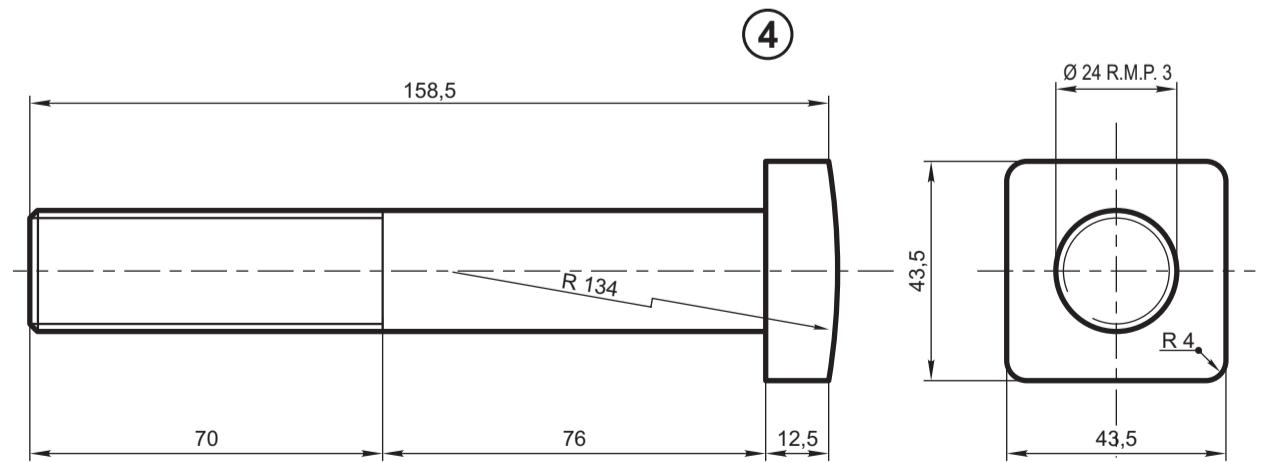
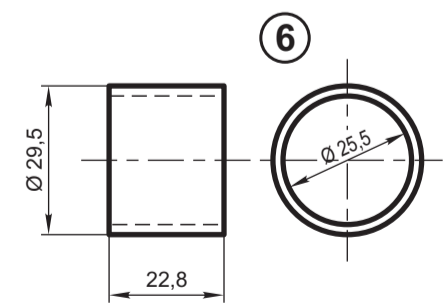
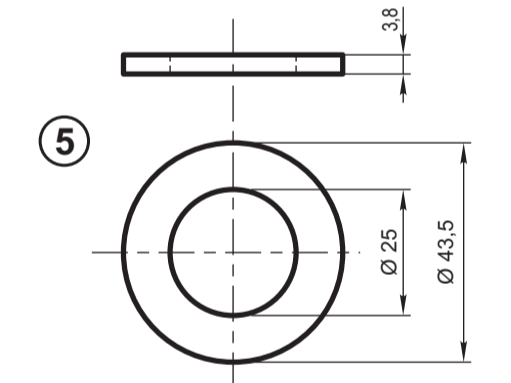
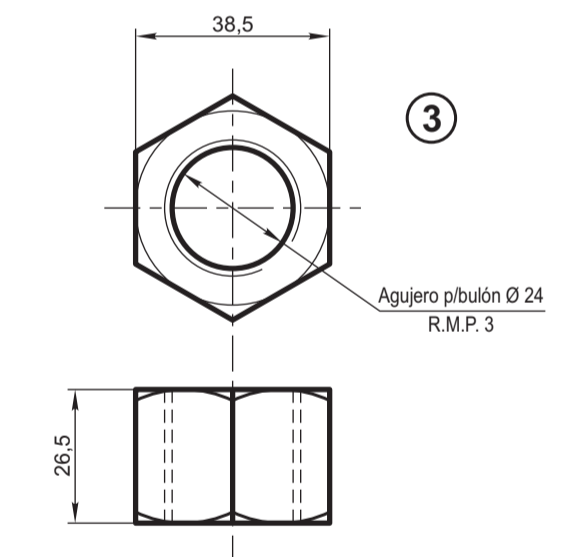
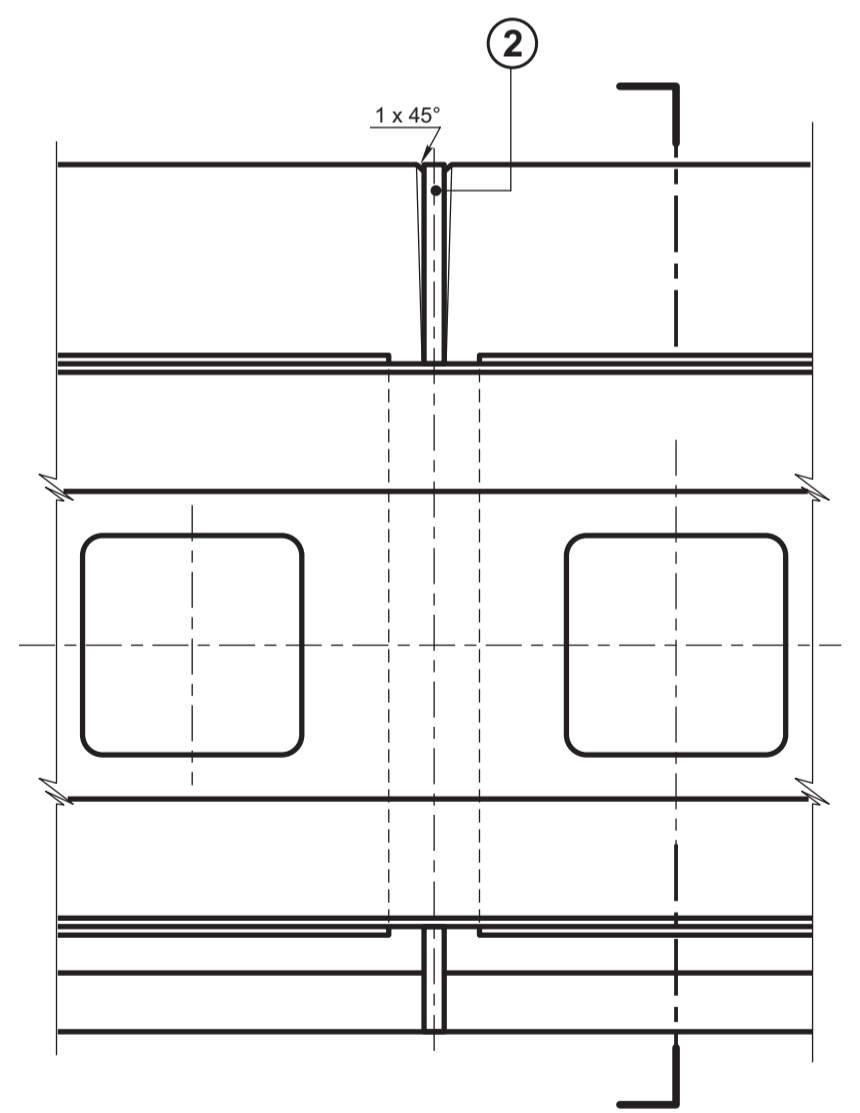

Tolerancia General entre Agujeros: ± 0,5  
Tolerancia General: ± 1

ITEM	CANT.	DESCRIPCION	MATERIAL Y OBSERVACIONES	NOMENCLADOR
8		Riel Perfil U.I.C. 60	60 kg/m	
7		Mortero sintético	Resina Termoestable	
6	6	Tubo aislante	Micarta	
5	6	Arandela	Acero SAE 1020	
4	6	Bulón	Acero SAE 4340 - Calidad 10.9-HRc38	
3	6	Tuerca	Acero SAE 4340 - Calidad 10.9-HRc38	
2	1	Perfil intermedio	Micarta	
1	2	Eclisa aislada	Acero SAE 1040 - (a) Micarta	

**JUNTA AISLADA PEGADA PARA RIEL U.I.C. 60 SISTEMA ALEMAN - 6 AGUJEROS**

FERROCARRAILES ARGENTINOS  
AREA VIA Y OBRAS

ESCALA	TROCHA	LINEAS:	UTILIZACION	EMISION
1:1,5	TODAS	TODAS	VIA	1
FIRMA Y FECHA APROB.		N° DE PLANO		
		G.V.O. 1713-2		