

Esc. 1:1

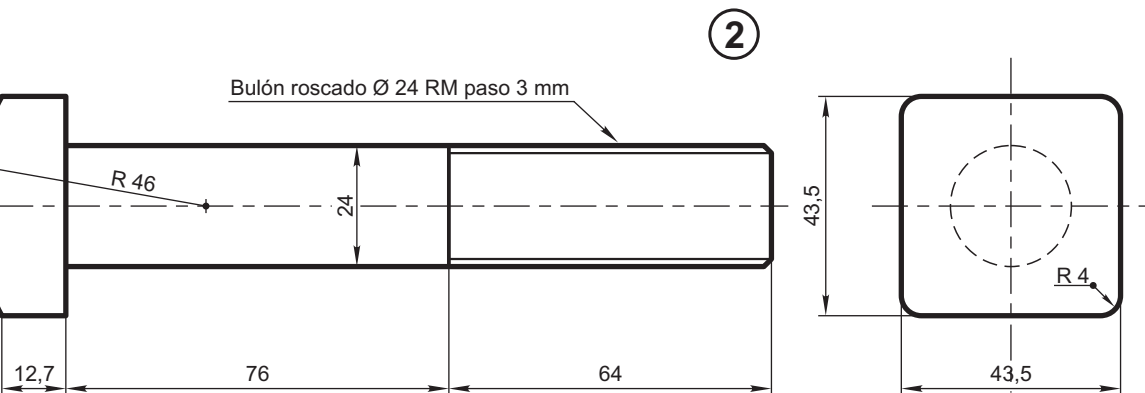

2

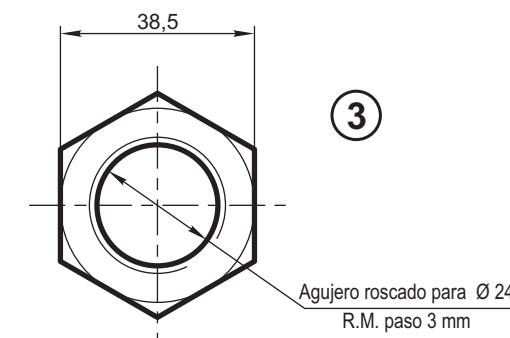

3

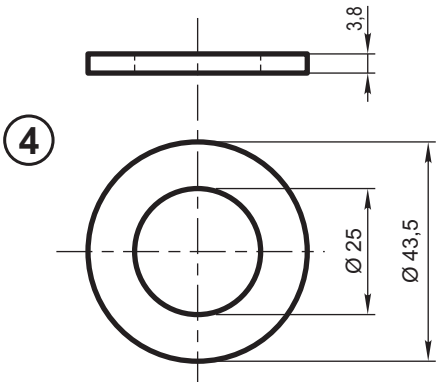

4

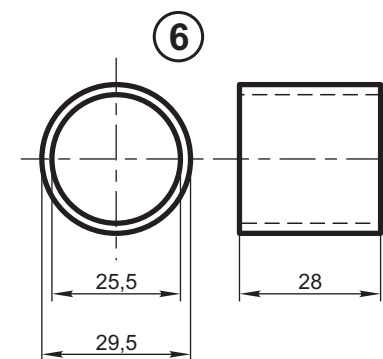

6

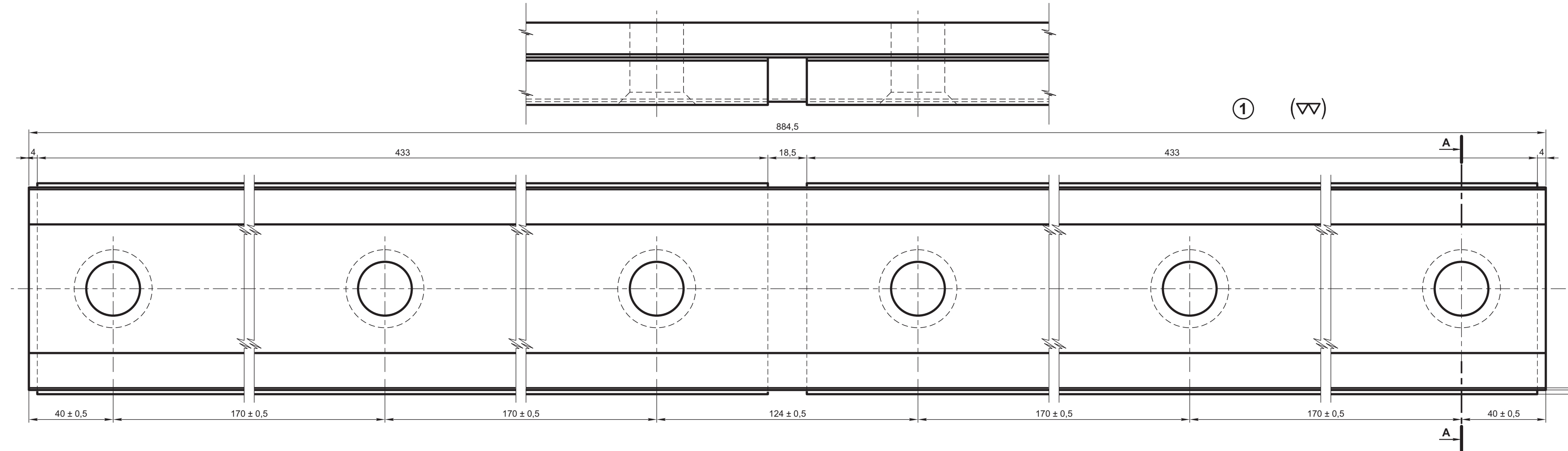

1 (VV)

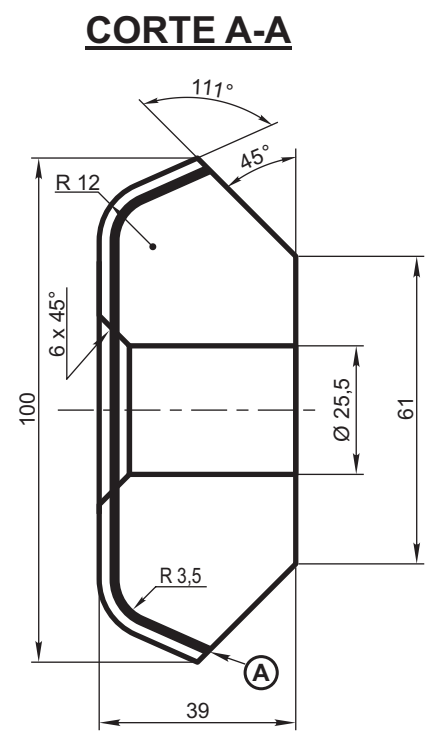

CORTE A-A

ITEM	CANT.	DESCRIPCION	MATERIAL Y OBSERVACIONES	NOMENCLADOR
6	6	Tubo aislante	Micarta	
5	1	Perfil intermedio	Micarta	
4	6	Arandela	Acero SAE 1020	
3	6	Tuerca	Acero SAE 4340 - Bulón Calidad 10.9 (HRc 38)	
2	6	Bulón	Acero SAE 4340 - Bulón Calidad 10.9 (HRc 38)	
1	2	Eclisa aislada	Acero SAE 1020 - (A) Micarta pegada	

DIBUJO: Mónica Ballochio
 REVISOR: Carlos Monteverdi
 AREA VIA Y OBRAS: Ing. Carlos Cortés

JUNTA AISLADA PEGADA PARA RIEL PERFIL U.36 Y U.50 6 AGUJEROS

AREA VIA Y OBRAS

CMRT

EMISION 1

ESCALA: 1:1,5 TROCHA: TODAS LINEAS: TODAS UTILIZACION: VIA

FIRMA Y FECHA APROB. 30 OCT 2009 N° DE PLANO GST (VO) 027

Ing. Horacio Faggiani a/c Gcia. de Seguridad en el Transporte