

CONJUNTO
Es. 1:2,5

DETALLE PIEZAS 1 Y 2

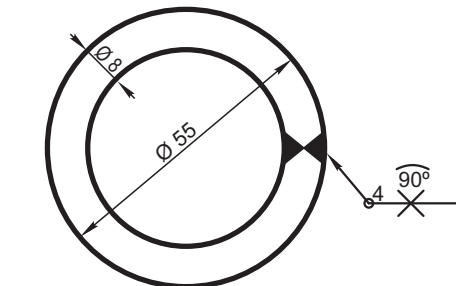

DETALLE PIEZA 6

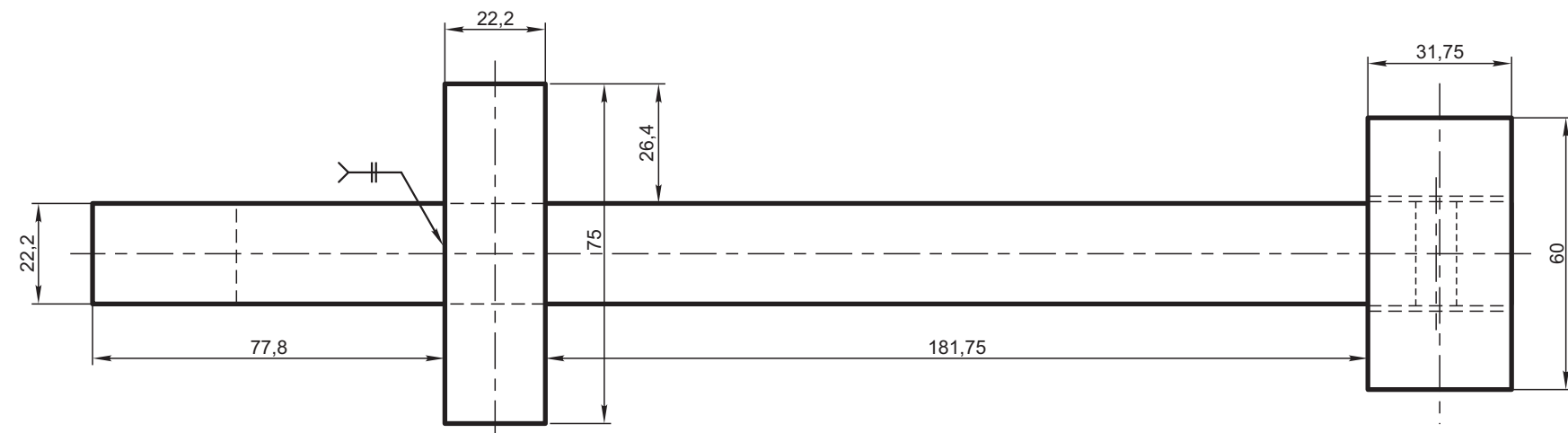
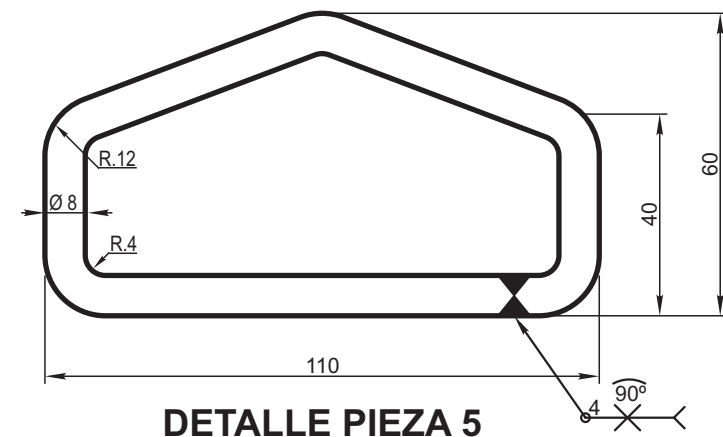

DETALLE PIEZA 5

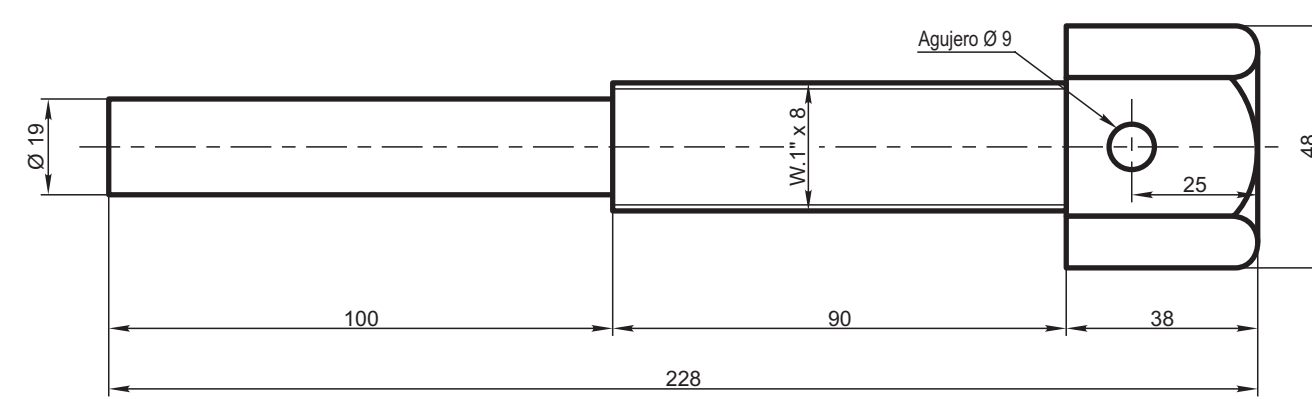

DETALLE PIEZA 3

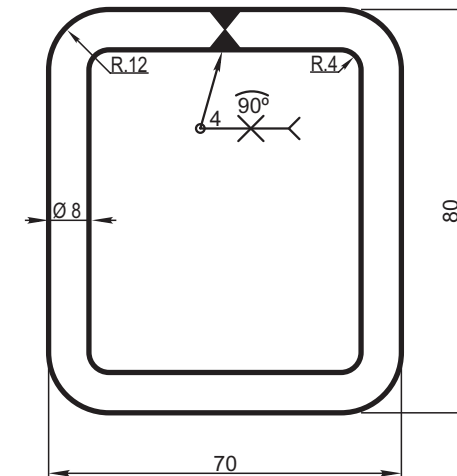

DETALLE PIEZA 4

N°	DENOMINACION	CANT.	MATERIAL
7	Cadena Ø 8 x 30 x 42 x 500	1	Comercial
6	Anillo	1	SAE 1010/20
5	Manija	1	SAE 1010/20
4	Anillo	1	SAE 1010/20
3	Tornillo cabeza hexagonal	1	F.24 o ST 37 1
2	Ojal roscado	1	F.24 o ST 37 1
1	Gancho	1	F.24 o ST 37 1

DIBUJO Mónica Billoccchio Miguel Materolo Ing. Carlos Cortés	REVISO: AREA VIA Y OBRAS:	GRAPA DE PERNO PARA ASEGURAR CAMBIO				CNRT	
						AREA VIA Y OBRAS	
Fecha: 02/03/2018	REVISO:	ESCALA 1:1,5 - 1:2,5	TROCHA	LINEAS:	UTILIZACION VIA	EMISION 1	
FIRMA Y FECHA APROB. <i>Horacio Faggiani</i> 16/03/2018 Ing. Horacio Faggiani Gerente de Control Técnico Ferroviario		N° DE PLANO GCTF (VO) 053					